

Products Overview



Your trusted partner in process instrumentation

Process monitoring, alarm and shutdown applications

World class technical solutions - proven technology - meeting international standards

Pressure Switch Instruments

Reputation for Excellence

Delta Mobrey is a leader in the design and manufacture of robust, reliable and competitively priced switch instruments - internationally approved for use in hazardous areas or safety systems for process control, safety alarm and shutdown applications.



An extensive range of certifications are available to various

- International
- European
- North American
- Russian (CU TR)

with **Explosion Proof** or **Intrinsically Safe protection mode**. We offer products independently Certified for **SIL 2** and **SIL 3** Safety Circuits.

Our switch instruments are ideally suited to a broad range of applications including:

Rotating machinery, pumping sets, fire protection systems, safety shutdown systems, valve actuation, boiler systems, wellhead panels, HVAC, nuclear safety applications, hydraulic control systems...

Utilising innovative design principles with highly reliable sensing elements such as Diaphragms, Pistons, Bellows, Bourdon Tubes and high quality engineering, over one million different temperature, pressure, differential pressure and flow switches have been supplied to customers worldwide.

Reliable - Dependable

Customers can depend upon the technical expertise and applications knowledge of Delta Mobrey engineers to understand their requirement and recommend cost effective, practical switching solutions.

Based on Delta Mobrey's proven technology, our switch products can operate within high and low end physical applications, and are designed to satisfy various site classifications and all significant industry approvals.

Delta Mobrey has built a specialist reputation for providing fully documented, customised switches for complex applications in hostile and demanding environments.





Pressure Transmitters

Delta Mobrey offers a full range of analogue or SMART HART digital transmitters featuring **ATEX, IECEX and SIL 2** Certified with a full range of accessories available including manifolds and chemical/diaphragm seals. Our instruments are regularly specified by operators world wide because of their compact size, rugged design and high standard specification.

Delta Mobrey's range of pressure transmitters includes **absolute, differential and gauge designs, with analogue or digital outputs**. High pressure up to 1,000 Bar for gauge pressure and best in class accuracy means Delta Mobrey can satisfy even the most demanding pressure applications over a wide temperature range. These can include static/one side pressure for the Differential pressure transmitters up to 420 Bar.



Pressure and Differential
Pressure Transmitters ▶

387 Analogue Transmitter ▶



2HT 'HART' Transmitter ▶





Temperature Measurement **Solutions**

Delta Mobrey offer a comprehensive range of quality assured temperature measurement devices that meet the highest recognised standards EN 60751, ANSI MC 96.1/EN 60584-2 across many industries including oil and gas, storage systems, nuclear power generation, food and pharmaceutical. Every product is designed and manufactured to offer a combination of maximum performance and minimal maintenance.

Rugged, reliable and accurate, our temperature range includes:

- Temperature switches
- Analogue and digital transmitters
- Gauges and local electronic indicators
- Thermocouples
- RTDs
- Flanged/Threaded thermowells, thermopockets, protection tubes, etc

Tailored solutions

Using its extensive in-house design and engineering facilities, Delta Mobrey temperature experts can customise standard products swiftly to meet individual technical requirements.





Level Controls

Horizontal Level Switch

Delta Mobrey float level switches are proven for tough process control duties in aggressive environments, trusted globally for long-term reliability and operation at high pressures and temperatures.



The horizontal level switch design features:

- Proven design with dependable reliability
- Magnetically coupled float and switch (no glands or linkages to cause leaks)
- Snap action switching, for clean make or break switching
- Option of a hermetically sealed switch mechanism to eliminate potential of freezing or corrosion of contacts

An extensive range of certifications are available, including:



Vertical Level Switch

Whether for critical area or general-purpose applications, the extensive range of Delta Mobrey vertical level switches ensures you will always have a quality and reliable solution to your problem.



The vertical level switch design features:

- Trusted 3 magnet switch mechanism
- Snap action latching and switching, time after time
- Option of a hermetically sealed switch mechanism for use in corrosive atmospheres and low temperature environments

Explosion Proof Certifications:



MLT100 Displacer Level Transmitter

The Delta Mobrey MLT100 Level Transmitter couples the time proven buoyancy principle with a 4 - 20mA output to transmit level or contents in a vessel and supports the HART protocol.

Special care has been taken in design to ensure a small mounting envelope is maintained, resulting in reduced weight and associated savings in mounting.



Typical applications include:

- Condensate drums
- Knock-out pots
- Storage vessels
- Separators

Explosion Proof Certification:





Sludge & Slurry Measurement

Ultrasonic Gap Sensors

The Delta Mobrey range of Ultrasonic Gap Sensors are widely used to discriminate between immiscible liquids to indicate the interface, and to detect and monitor suspended solids in numerous applications.

MCU200 and Gap Sensors

Interface Detection

The techniques of ultrasonic attenuation and ultrasonic refraction can detect an interface between two immiscible liquids, such as oil and water.

Sludge Measurement

Solids suspended in a liquid will scatter ultrasonic beams, causing attenuation. This principle can be used to detect sludge blankets in Clarifiers and Municipal water Primary and Secondary settlement tanks. Sensors and controllers can be used for pump control, or high sludge level alarm.



MSM400 and ATEX Gap Sensors

Many years of practical experience have shown that measurement of ultrasonic attenuation in a slurry is directly proportional to the percentage of suspended solids. The MSM400 system uses this principle to produce a continuous digital display of the suspended solids measurement contained in, or flowing from a clarifier or settlement tank during de-sludging.



Solids Level Detection Switches

Both rotating paddle switch and vibrating rod level switch can be used with powders or bulk solids to provide high or low-level alarms.

Rotating Paddle Level Switch (PLS)

A motor drives a paddle to rotate slowly. The paddle stops when a solid medium is present. When the solids level falls, the paddle turns and the output signal changes state.

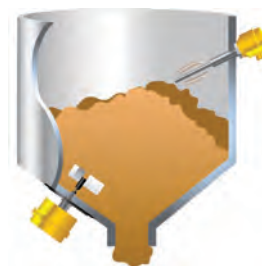

Vibrating Rod Level Switch (VLS)

A rod is driven to vibrate continuously. When surrounded by a powder or solid medium, the frequency of vibration changes and once detected this causes a relay to switch.



Steam Boiler Water Level

Hydrastep 2468 Steam Drum Level Measurement for Water Tube Boilers

With diagnostics to detect all fault conditions and over 6,000 installations globally, the Delta Mobrey Hydrastep steam drum level measurement for water tube boilers ensures no single fault will defeat the system.

Failure to detect low water levels in steam-raising plant can have costly and potentially disastrous consequences. Reliable water level detection is vital to prevent damage to plant and personnel.

Trusted globally for over 50 years, the Hydrastep electronic gauging system is the ideal 'fit and forget' solution to overcome the problems associated with unreliable and maintenance-intensive gauge glasses.

- Fault tolerant and fail-safe design
- Alarms or trips for low / high-water conditions will not trip the boiler on a false alarm
- Electrodes available for up to 560 °C (1,040 °F) and 300 Bar (4,350 PSI)
- High clarity local and remote displays for control room
- 4–20 mA output proportional to water/steam interface level

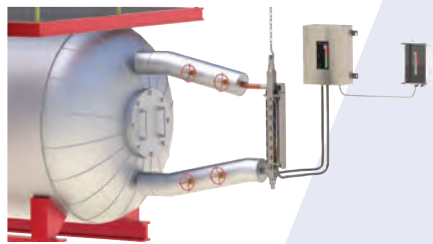

Independently Validated Assessment

An independent report by Factory Mutual Research concluded that the statistical probability of Hydrastep missing a trip condition is less than 1 in 300 million and that nuisance trips will be less than 1 in 10 million.

- ASME approved design
- Hydrastep start-up, commissioning, maintenance services available

Steam and Water Detection

Hydratect 2462 Steam and Water Detection System

The electronic alternative to conventional water level switches, the Delta Mobrey Hydratect 2462 detects the unwanted presence of steam or water in safety critical applications.

- High reliability system for water detection in steam lines
- Typical applications include: high and low-level alarms and trips on steam drums, feed heaters, de-aerators, condensate pots, and turbine water induction prevention system (TWIP) on steam lines.
- Electrodes for use up to 560 °C (1,040 °F) and 300 Bar (4,350 PSI)
- Relay outputs in varying options, for status and fault alarms

The Hydratect electronic water and steam detection system is widely used in a wide variety of applications wherever the detection of water or steam is vital for safe and efficient plant operation.

The highest standards of reliability are achieved by using a combination of error detection, triple redundancy, and a fail-safe design.

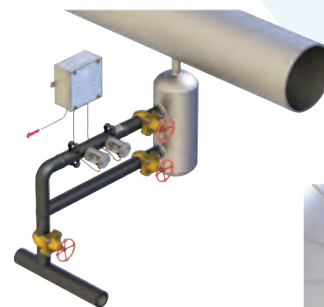

◀ Level detection in condensate pots

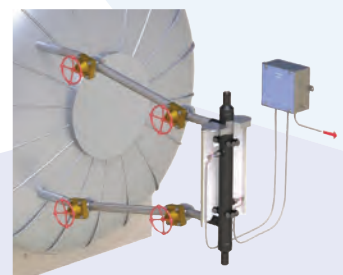

High and low alarms and trips for steam/water level ▶



Boiler Controls

Low Pressure Steam Boiler Level Controls

Range of boiler water level controls for shell boilers, up to 32 Bar saturated steam, either chamber mounted, or directly mounted onto the boiler shell.

- 13, 21 & 32 Bar pressure ranges
- First low-level alarm
- Second low level alarm
- High level alarm
- Pump on/off control
- Modulating feed water control



Feedwater Control & Blowdown Valves

- Associated feedwater control and blowdown valves complement the Delta Mobrey float level controls.



On Site Services

Field Service Division

The field support division of Delta Mobrey offers engineering design, supply, installation, commissioning, calibration and on-going servicing of both Delta Mobrey and other manufactures' products.

With the experience and capabilities to provide a complete turnkey solution, the normal complexities with multi-discipline projects and maintenance works can be kept to a minimum - and long-term operational requirements are correctly maintained.





Flow Measurement

Vortex Shedding - Accurate - Reliable

Delta Mobrey's range of vortex shedding flow transmitters feature compact designs with no moving parts, offering high accuracy with exceptional reliability and repeatability. Delta Mobrey's flow transmitters offer a compact, high accuracy and cost effective flow measurement solution.

In the Automotive industry, Delta Mobrey's flow transmitters are specified for engine test bed facilities by engine manufacturers and lubricating oil developers. More accurate than traditional measuring methods such as rotameters, Delta Mobrey's flow transmitters offer a compact, high accuracy and cost effective solution.

The Delta Mobrey flow meter has also been EMPHASIS approved (the nuclear industry SMART Device Approval) and is available for all HVAC and gas flow applications.



Orifice Flanges

The calibrated orifice flange is one of the most simple and economic methods for the flow measurement of liquids or gases. Delta Mobrey can supply a wide range of different types of primary elements, from the basic simple orifice plate to the complete measuring system. With our D-SERIES digital SMART Hart differential pressure, pressure and temperature transmitters, having a base accuracy of 0.075%, we can provide an accurate and complete compensated gas flow measurement system.

Meter Run

- Meter Run manufactured according to AGA-ASME, UNI, DIN, BS
- Standard material 316 Stainless Steel, however exotic materials available (Monel, Hastelloy, etc)
- Flow calculation sheet supplied as standard
- Wide range of applications at medium and high pressures and temperatures



Venturi Tubes

- Used when low pressure drops are required
- Manufactured in sizes from 2" to 48" according to A.S.M.E. and ISA

Pitot tubes for very low pressure applications

- Manufactured according to AGA-ASME
- Various material available, from the standard material 316 Stainless Steel to meet high temperature requirements on flue gas

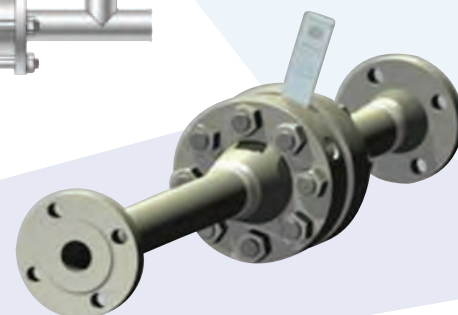
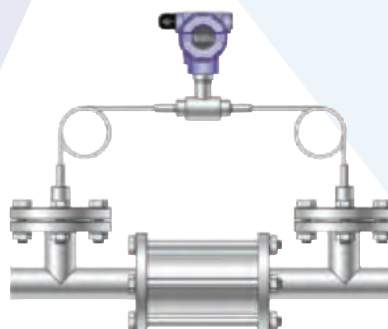



Instrument Gauges

Utilising our considerable experience of providing high quality instrumentation solutions to the worldwide process industry, Delta Mobrey offers a comprehensive range of instrument gauges.

These gauges are produced to the usual high specification and quality that process plant operators, engineering contractors and OEM customers demand and expect from Delta Mobrey.

We produce a wide range of all stainless steel local indicators for Safe or Hazardous areas as well as associated accessories.



1/2 G Dc

- Full compatibility to NACE standards
- Bourdon tube gauges Open or Solid Front for medium and high pressures up to 1,000 Bar as standard
- Capsule and Diaphragm types for low and medium pressure
- Differential pressure gauges
- Bimetal and Gas expansion temperature gauges up to 600 °C as standard
- All thermowells can be manufactured using ASME PTC 19.3 stress calculation in an extensive range of exotic materials
- Chemical/ Diaphragm seals for chemical, pharmaceutical, oil & gas, petrochem and food industry applications
- A full range of accessories are available - electric contacts, over-range protectors, snubbers, pigtail siphons, thermowells





Products for **Nuclear Applications**

Delta Mobrey has been designing and manufacturing instrumentation for the power and process industries since 1950 and has served the nuclear industry in the UK since the first commercial reactors in the 60's, as well as internationally for over 45 years. A specialist in pressure, level, temperature and flow sensors, Delta Mobrey has provided a range of generic and bespoke instruments to the industry across all the UK Nuclear Power Plant (NPP) and a number of International NPP in a wide variety of applications.

Available products include Class 1E switches, meeting both IEEE and RCC-E requirements for Nuclear Island use as well as a complete range for Conventional Island and Balance of Plant applications. Delta Mobrey also has the HAF604 approval from the Chinese NNSA for products for the Nuclear Island.

Delta Mobrey's range consists of:

- **Pressure Instruments**
 - Transmitters and Switches
 - Absolute, Gauge, Differential
- **Level Instruments**
 - Transmitters and Switches
- **Temperature Instruments**
 - Switches, Transmitters, RTD's
- **Flow Instruments**
 - Transmitters - Insertion/In-Line, Switches

In addition, Delta Mobrey offers its nuclear customers:

- Excellent performance, reliability and an accuracy that is class leading
- A bespoke service to solve problems and find solutions to technical challenges
- Alternative products for obsolete instruments replacing aged competitor units no longer supported
- Life Extension or Safety Case projects to ensure reactor safety monitoring systems perform to latest requirements

Solutions to Special Applications, examples of which include:

- Fast response Leak Detection within the containment area (HELB)
- Fast Response air temperature switches
- Flow rate monitoring
- High Static pressure - low set point - high pressure reversal applications
- Low pressure and low deadband differential pressure switches
- Self Cleaning low Dead Band high accuracy switch for main feed water cooling system





About Delta Mobrey

With a proud history spanning over 100 years, Delta Mobrey Limited is a recognised global specialist in the design & manufacture of quality process instrumentation for the measurement and control of fluid and gases in all industrial plant and equipment.

Trusted Quality. Reliable Dependence.

Quality and reliability have always formed the cornerstone of the company's success, recognised by industry with international approvals covering every aspect of our manufacturing, test and product portfolio.

Certifications span all areas of hazardous and regulated environments, and include: ATEX, IECEx, EXd, EXia, NEMA, SIL, IS, PED, CU TR, NEC 500 and 505, with new certifications continually being gaining.

Proven Value

Performance and value - the reason why so many customers return and continue to place their trust in Delta Mobrey products. With continual investment in innovative manufacturing solutions, customers can be confident we can deliver the highest value solutions, without ever compromising on quality.

Industry Expertise

With many millions of instruments installed worldwide, Delta Mobrey are considered one of the foremost authorities worldwide across a span of process industries.

- Oil and Gas - offshore and onshore - exploration, production, refining and distribution
- Power Generation including nuclear - steam raising plant, turbine generators, fire protection systems, safety shut down systems
- Water Treatment
- Petrochemical and Chemical
- Pharmaceutical
- Food and Beverage
- Pulp and Paper

Bespoke Solutions

In addition to offering over 1 million standard product variants, Delta Mobrey can also provide custom engineered solutions to meet your exact requirements.

The complexity of special engineering can vary from a simple change in process connection to a completely redesigned product to meet specific operational or performance criteria - available in one-offs through to large volume requirements.



Delta Mobrey Limited

Riverside Business Park, Dogflud Way, Farnham, Surrey, GU9 7SS, UK

T +44 (0) 1252 729140 F +44 (0) 1252 729168 E sales@delta-mobrey.com W www.delta-mobrey.com



www.southerninstruments.com.au

+61 3 97493676



FM00720